

GALLIPOLI divano AGAL

pag. 22/23



DIVANO GALLIPOLI

RIVESTIMENTO: 40DE07226 CAT E MAZZA APULIA

CUSCINETTI: 40DE6528 CAT B MAZZA LUCE

METALLO: A04 CARTELLA PRISMA

DIVANO POLIGNANO

RIVESTIMENTO: 40DE07226 CAT E MAZZA APULIA

CUSCINETTI: 40DE6528 CAT B MAZZA LUCE

METALLO: A04 CARTELLA PRISMA

SGABELLO TURI

RIVESTIMENTO: 40MO07224 CAT F MAZZA APULIA

METALLO: A04 CARTELLA PRISMA

LAMPADA ART M158

FINITURA: LAMPADA DA TAVOLO IN VETRO SOFFIATO
CON BASE IN METALLO FINITURA NICHEL E DIFFUSORE IN TESSUTO NERO

PIANTANA ART M164

FINITURA: VETRO IN TITANIO, STRUTTURA IN METALLO NICHEL

POLTRONA TORITTO

RIVESTIMENTO: 40DE07226 CAT E MAZZA APULIA

FINITURA: P1012 CARTELLA PRISMA

TAVOLINO MOLA

TOP: MARMO CALACATTA

METALLO: A04 CARTELLA PRISMA

TAPPETO

FINITURA: 100% VISCOSA, METODO HANDTUFTING

BOISERIE TURI

FINITURA: P1012

METALLO: A05 CARTELLA PRISMA

pag. 26/27



DIVANO GALLIPOLI

RIVESTIMENTO: 40MO07228 CAT F MAZZA APULIA

CUSCINETTI: CANOVA COL 565 / 40DE07374 CAT B MAZZA EASY

METALLO: A05 CARTELLA PRISMA

POLTRONA PESCHICI

RIVESTIMENTO: 40MO07228 CAT F MAZZA APULIA

CUSCINETTI: CANOVA COL 565 / 40DE07374 CAT B MAZZA EASY

METALLO: A05 CARTELLA PRISMA

PIANTANA ART M164

FINITURA: VETRO IN TITANIO, STRUTTURA IN METALLO NICHEL

TAVOLINO CORATO

TOP: MARMO CALACATTA

METALLO: A05 CARTELLA PRISMA

TAPPETO

FINITURA: 100% VISCOSA, METODO HANDTUFTING

Versione: come da schede tecniche
Struttura: legno e i suoi derivati;
cinghie elastiche incrociate ad alta
resistenza.

Imbottitura: in poliuretano espanso
a quote e qualità differenziate, fibre
poliestere.

Piedi: in acciaio inox

Caratteristiche: la finitura per la
parte in acciaio è disponibile nella
cartella "PRISMA".

*Versions: as shown in the technical
drawings*

*Structure: in wood and by-product;
high resistant strenght woven elastic
belts*

*Padding: expanded polyurethane of
differentiated densities and quality,
polyester texture.*

Feet: inox steel

*Characteristics: the finish for the
steel part is available in the "PRISMA"
folder*

GALLIPOLI divano

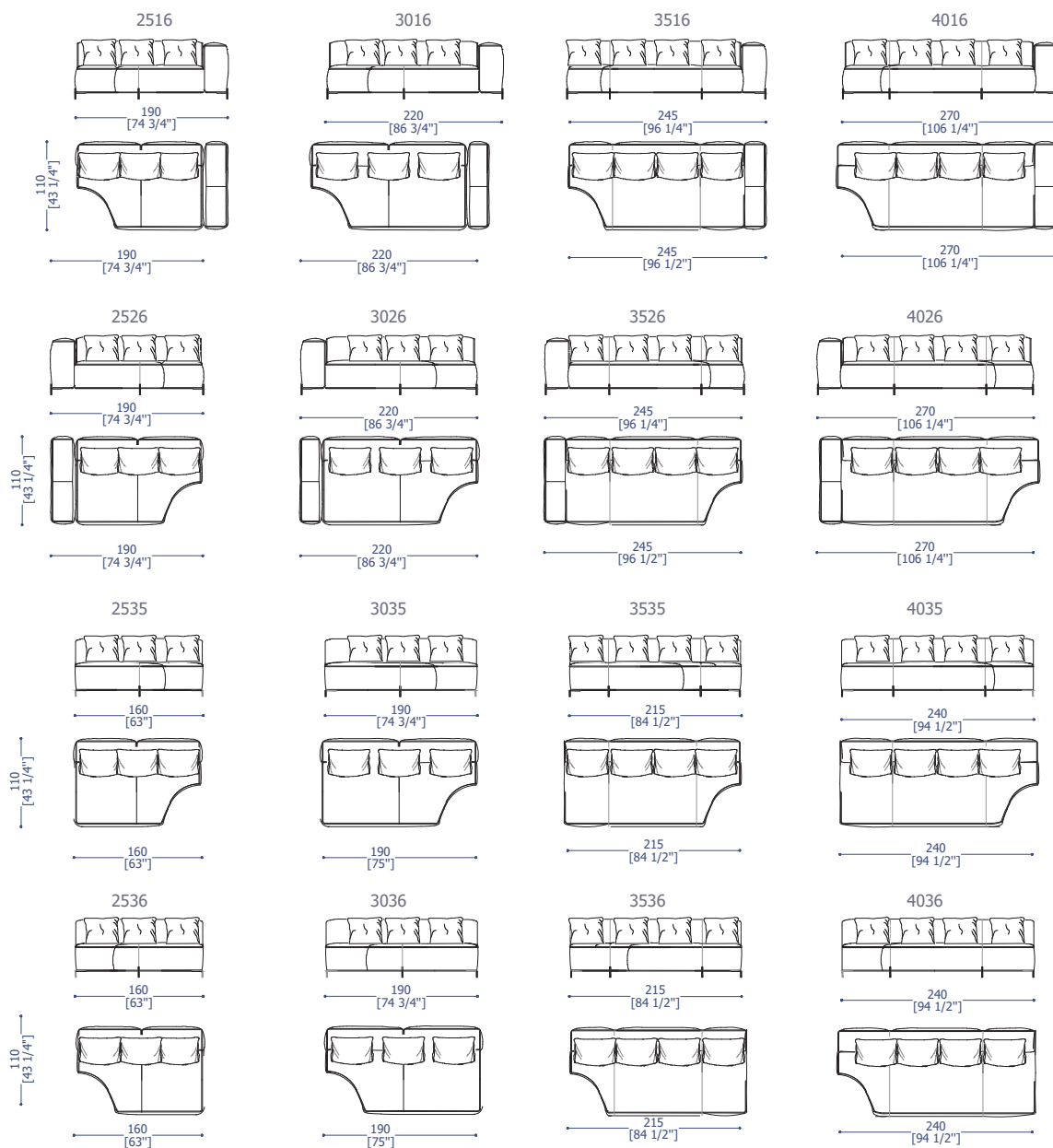
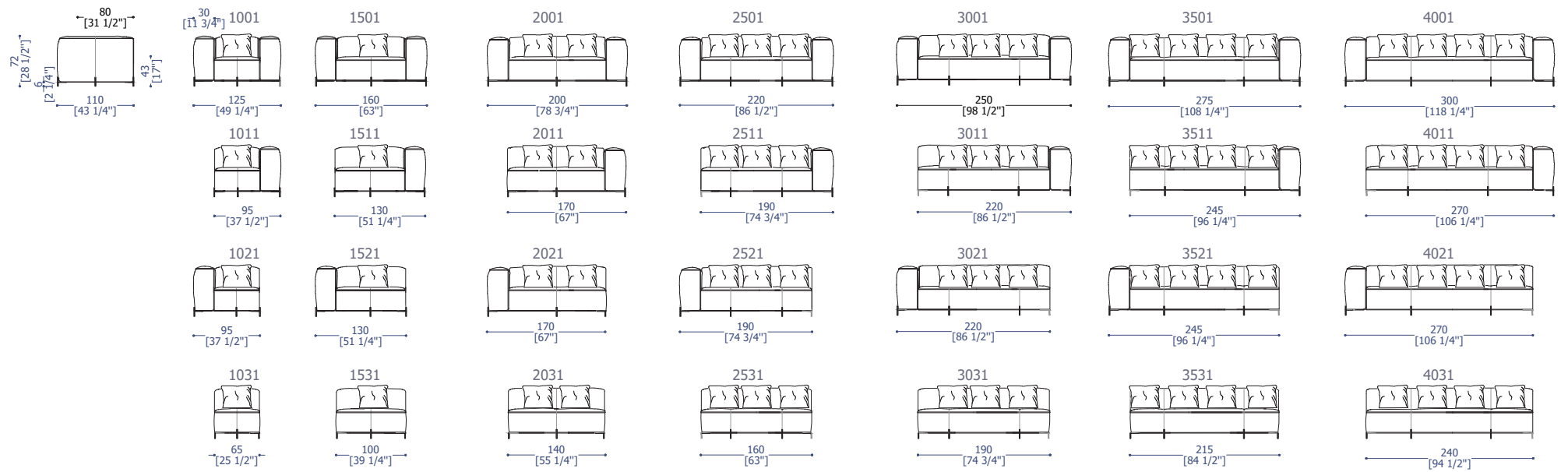

ANGOLO

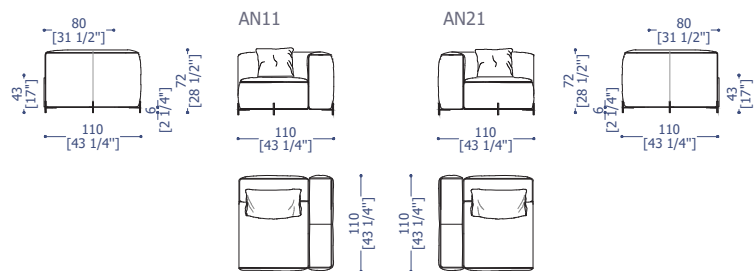

ANGOLO LUNGO

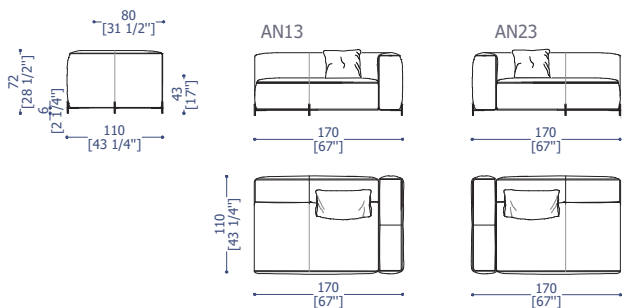

CL

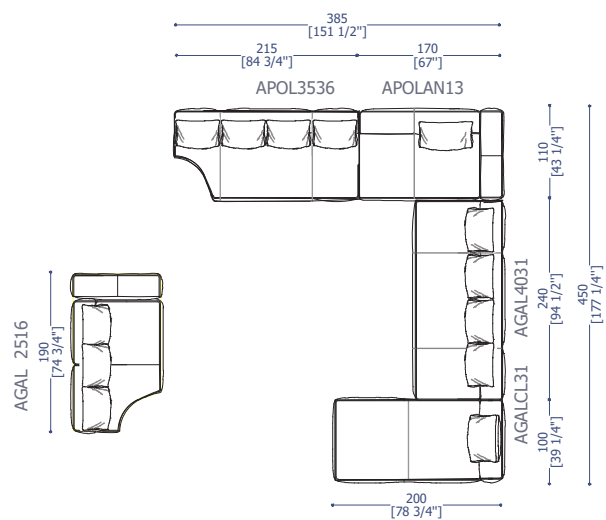
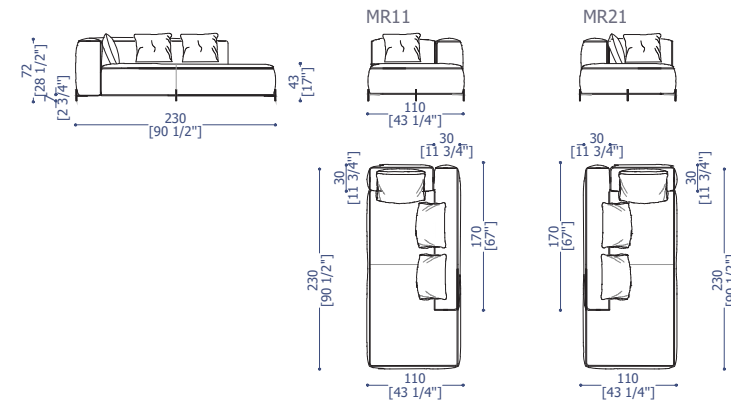
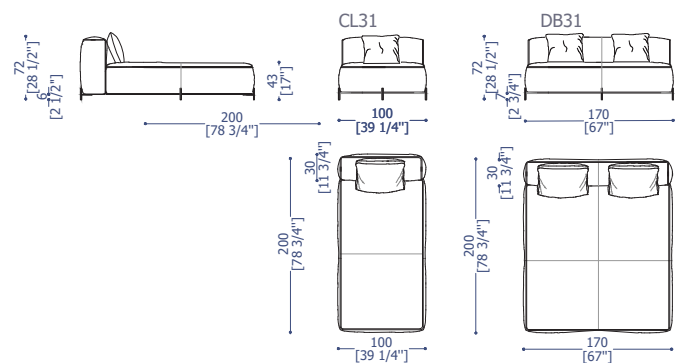

COMPOSIZIONE pag. 12/13

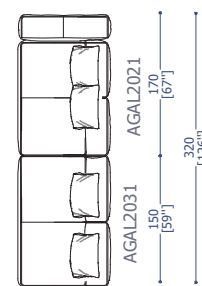
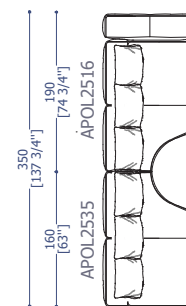

COMPOSIZIONE pag. 22/23

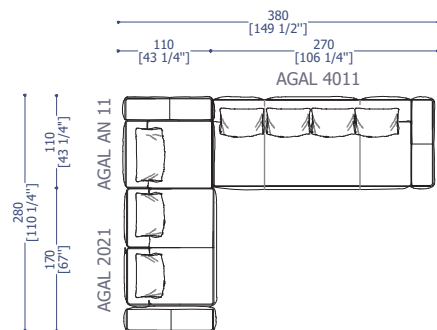

COMPOSIZIONE pag. 26/27