

# MORGANITE pouf EMOR

pag. 247 - 251

Versioni: pouf

Struttura: legno e suoi derivati,  
cinghie elastiche incrociate ad alta  
resistenza

Imbottitura: in poliuretano espanso  
a quote e qualità differenziate, fibre  
poliestere

Caratteristiche: base in acciaio,  
disponibile nelle finiture previste nella  
cartella "PRISMA"

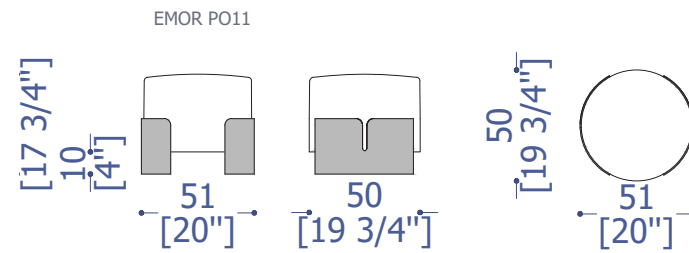

Versions: pouf

Structure: in wood and by-products,  
high resistant strength woven elastic  
belts

Padding: expanded polyurethane of  
differentiated densities and qualities,  
polyester texture

Characteristics: base in steel, steel  
finishing is available in different colors  
provided in the "PRISMA" folder

# MURGIA panca AMUR

pag. 233

Versione: Panca

Base: in essenza o laccata con  
inserto in acciaio inox

Imbottitura: in poliuretano espanso  
a quote e qualità differenziate, fibre  
poliestere.

Caratteristiche: le finiture del legno  
e dell'acciaio sono disponibili sono  
previste nella cartella "PRISMA".

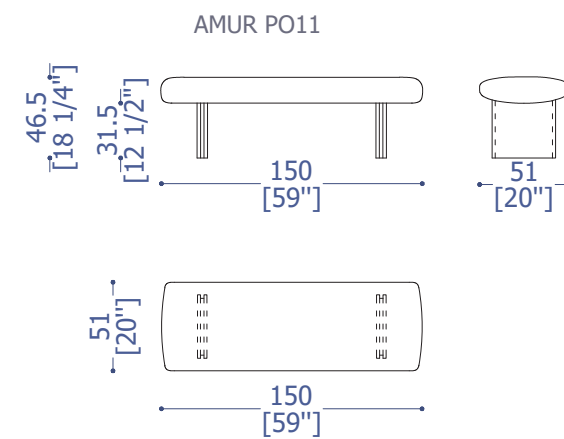

Versions: Bench

Base: wood's essence or lacquered  
wood with steel insert

Padding: expanded polyurethane of  
differentiated densities and quality,  
polyester texture.

Characteristics: the finish for the wood  
and steel parts are available in the  
"PRISMA" folder.