

# PORTO CESAREO divano APOR

pag. 86/87



## **DIVANO PORTO CESAREO**

**RIVESTIMENTO:** MAYA NABUCK COL  
7307 PIETRA CAT P4  
BRINA COL 5211 OCEANO CAT P2  
LEATHER COLLECTION

## **TAVOLINO MOLA**

**TOP:** MARMO BORGHINI  
**METALLO:** A05 CARTELLA PRISMA

## **TAPPETO**

**FINITURA:** 100% VISCOSA, METODO  
HANDTUFTING

## **LAMPADA ART M159**

**FINITURA:** LAMPADA DA TAVOLO  
IN CRISTALLO INTAGLIATO CON  
DIFFUSORE IN TESSUTO NERO

## **PIANTANA ART M164**

**FINITURA:** VETRO IN TITANIO,  
STRUTTURA IN METALLO NICHEL

## **CIANITE LIBRERIA E.CIA.B010**

**FINITURA:** P1044  
**METALLO:** A05 CARTELLA PRISMA

Versione: come da schede  
tecniche

Struttura: legno e i suoi derivati;  
cinghie elastiche incrociate ad  
alta resistenza.

Imbottitura: in poliuretano  
espanso a quote e qualità  
differenziate, fibre poliestere.

*Versions: as shown in the  
technical drawings*

*Structure: in wood and by-  
product; high resistant strenght  
woven elastic belts*

*Padding: expanded  
polyurethane of differentiated  
densities and quality, polyester  
texture.*

3035

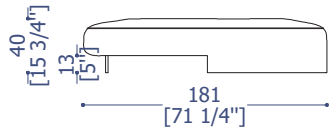
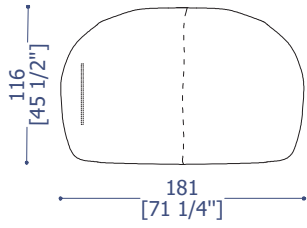

3535

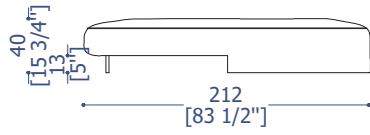
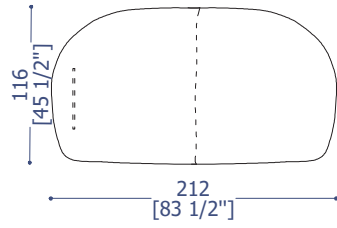

4035

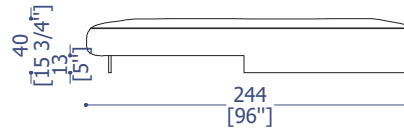
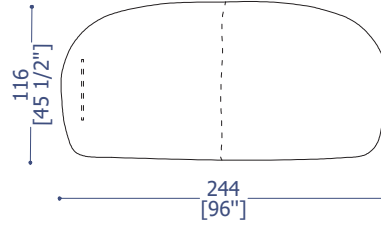

4535

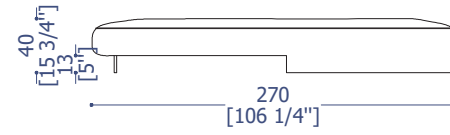
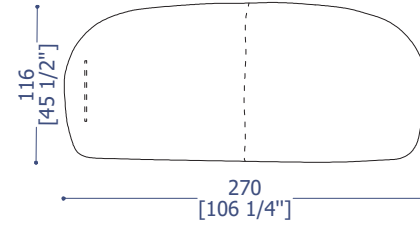

3036

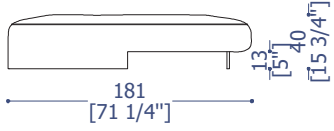
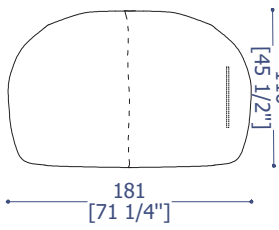

3536

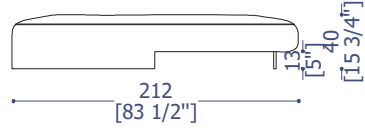
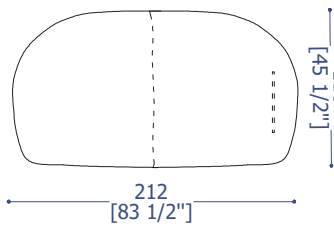

4036

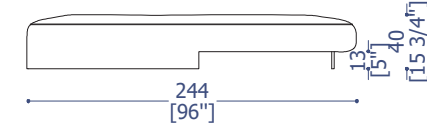
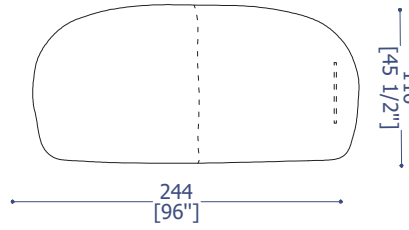

4536

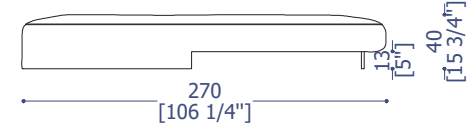
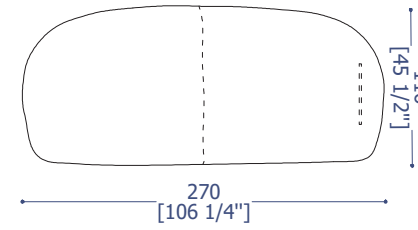

# PORTO CESAREO divano APOR

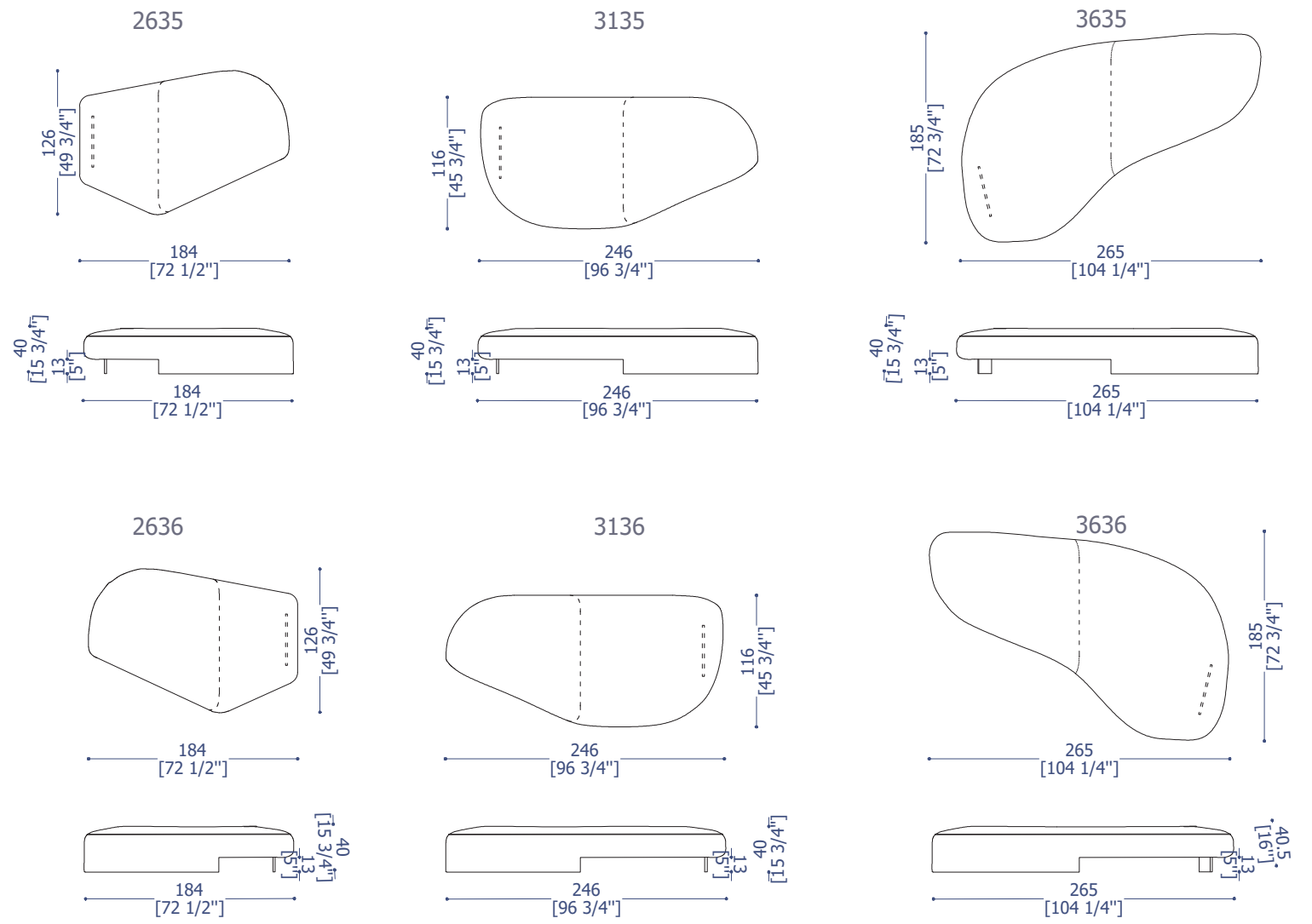

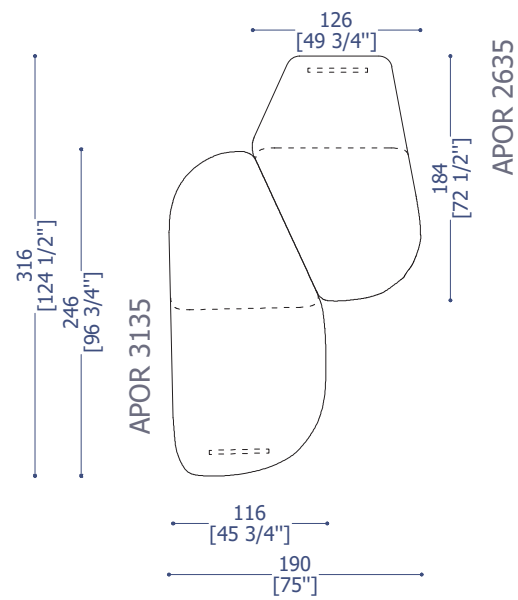
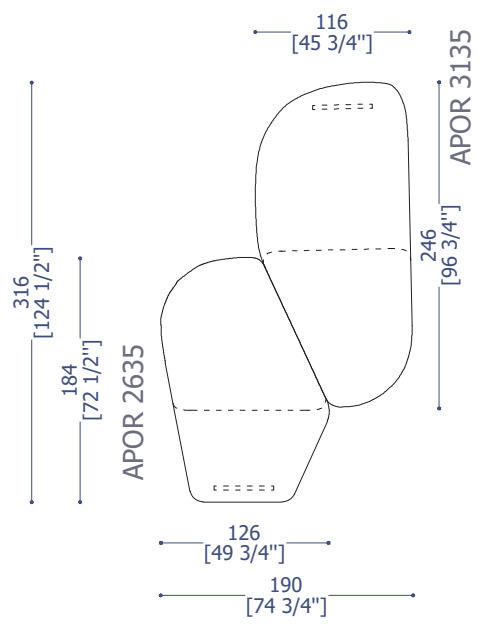
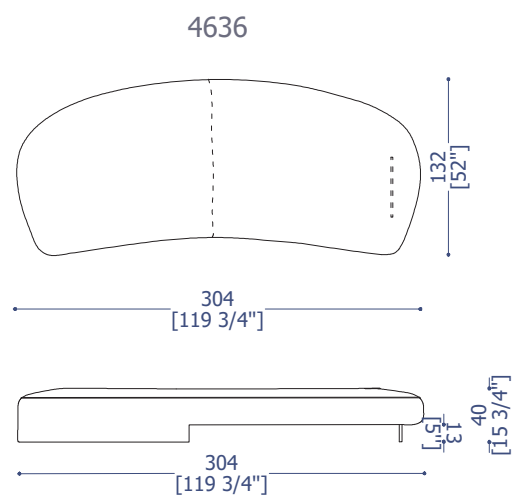
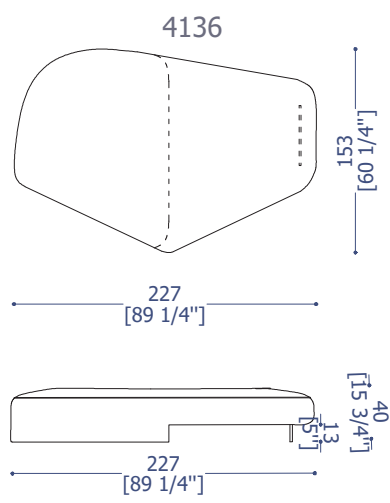
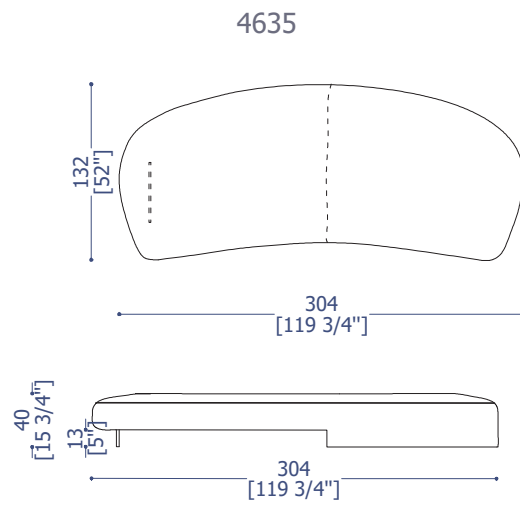
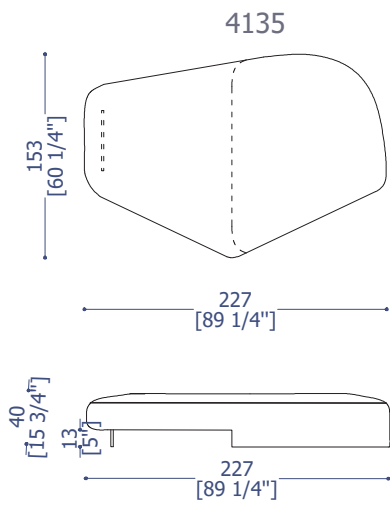

COMPOSIZIONE pag. 86/87